

---

# Ultra-High Resolution Mass Spectroscopy of Boron Cluster Ion Beams

IIT-2004  
October 29, 2004

*Dale Jacobson, Thomas Horsky, Wade Krull and Bob Milgate*

---

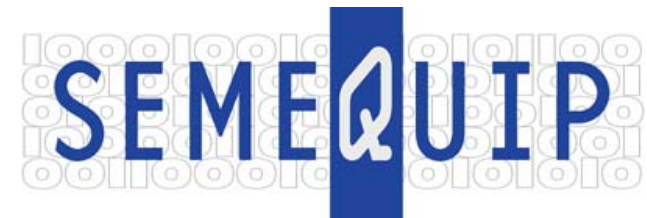

# Outline

---

- Equipment
- B<sub>18</sub>H<sub>22</sub> Mass Spectra
- Detailed Spectral Analysis
- The Effect a Multiple Mass/Multiple Energy Ion Beam Has on:
  - Depth Distributions
  - Angular Distributions

# SemEquip Test Stand

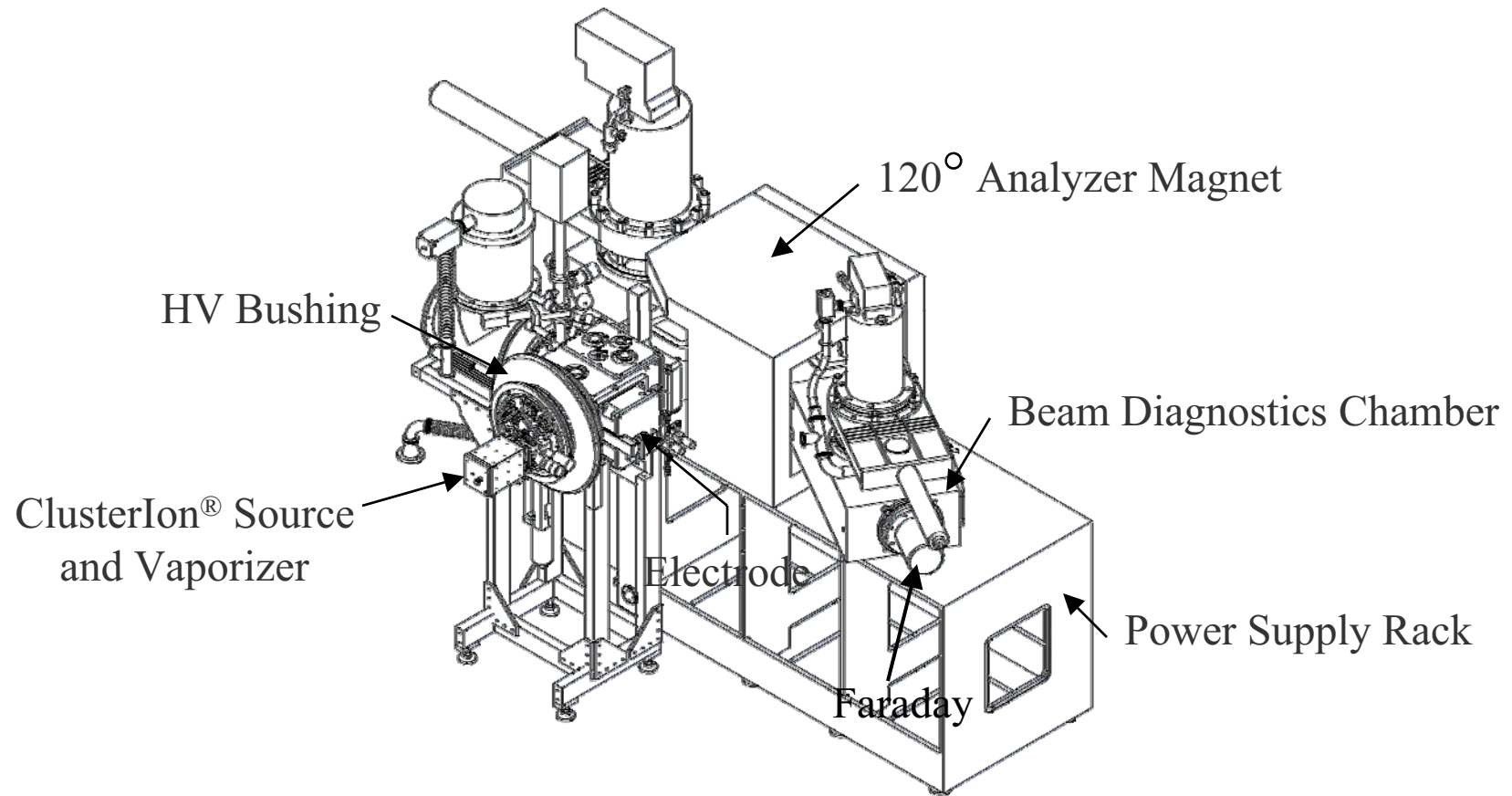

# Source Assembly Cross Section

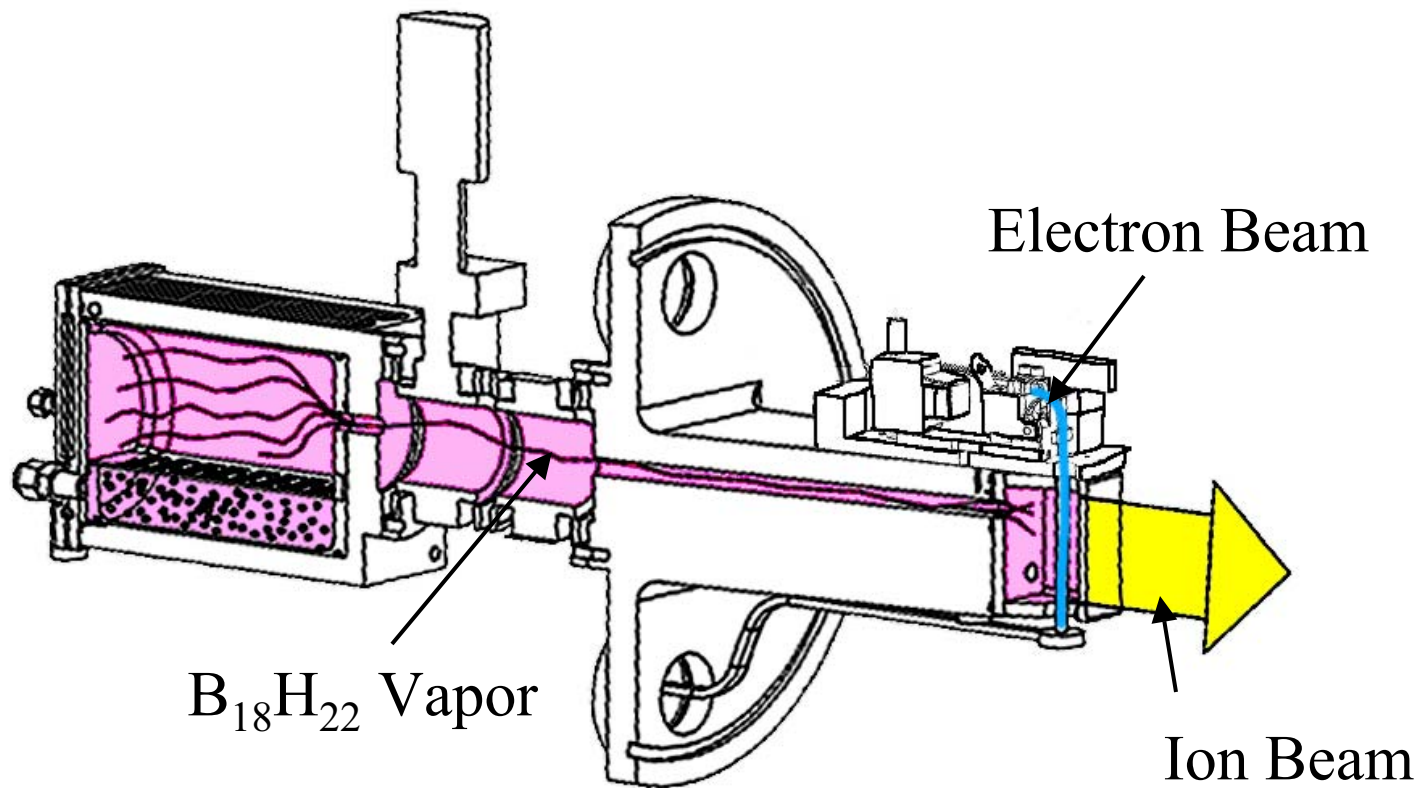

# The ClusterBoron™ Molecule

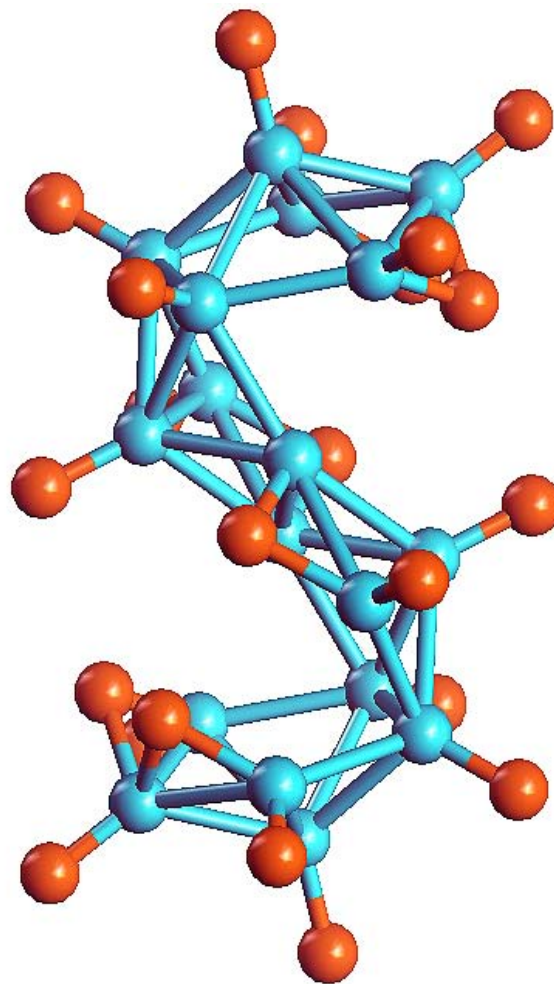

# Mass Spectrum

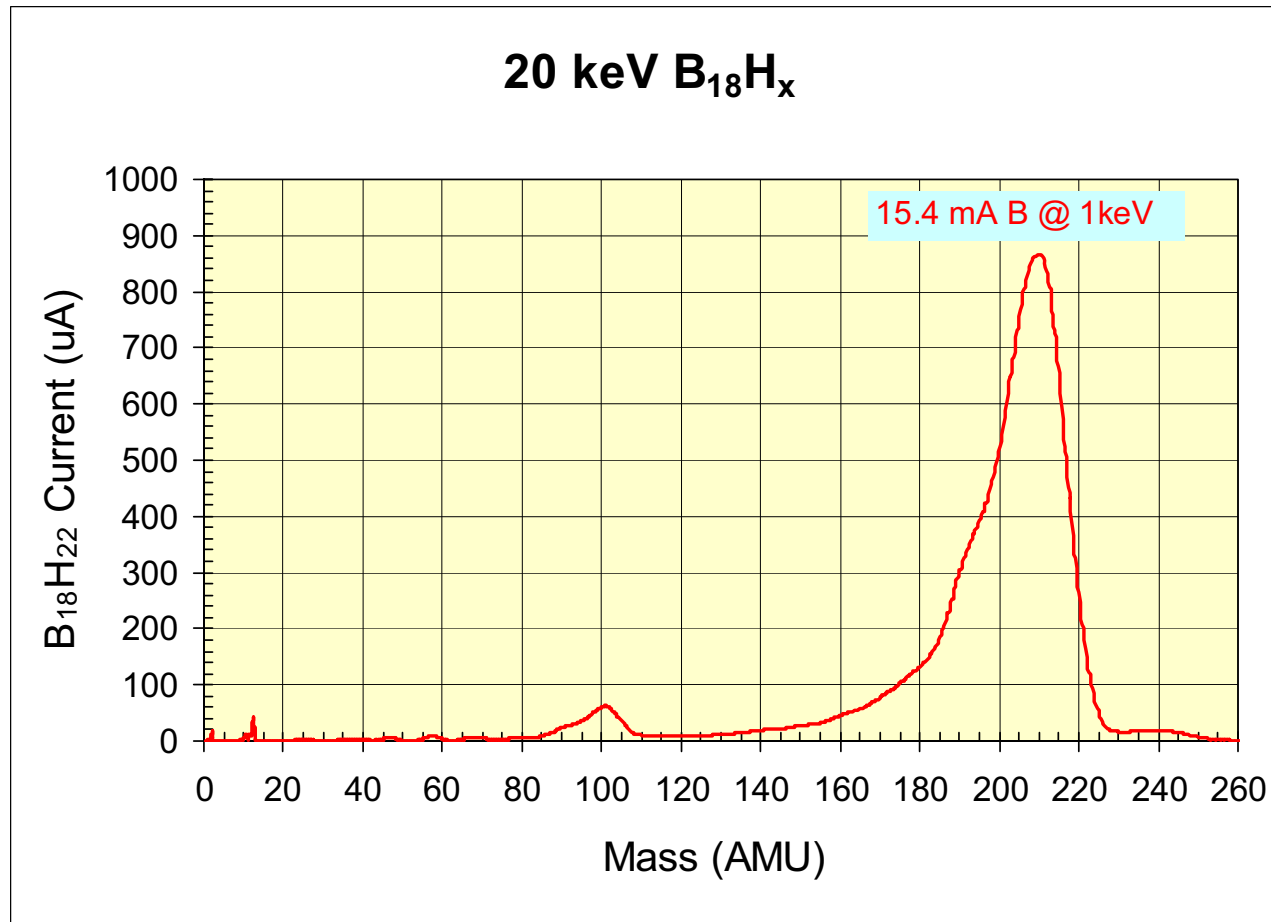

# Ultra-High Resolution Mass Spectrum

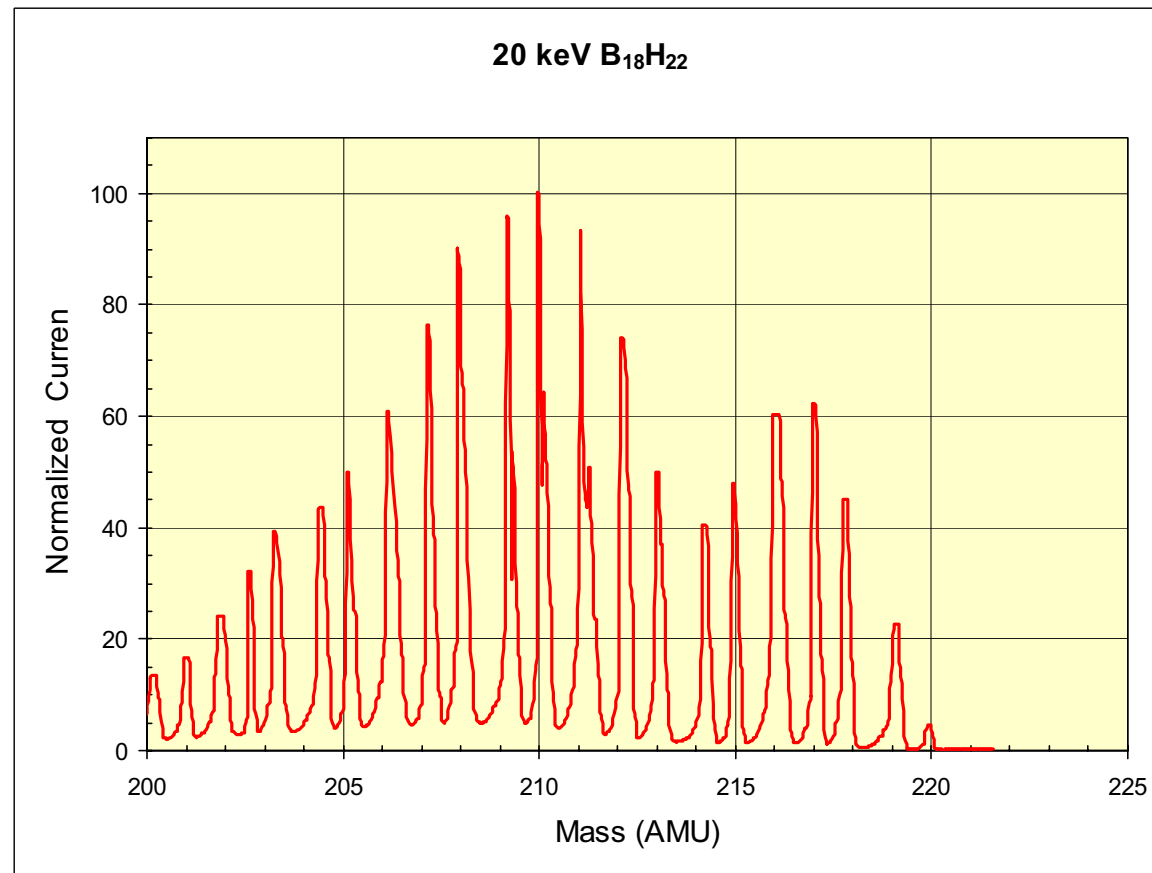

5 mm aperture at entrance to magnet, 0.5 mm Mass Resolving Aperture at focal plane

# Binomial Distribution

## 20% Mass 10 and 80% Mass 11 Boron

# of Mass 11atoms	# of Mass 10atoms	Relative Fraction
0	18	2.62E-13
1	17	1.89E-11
2	16	6.42E-10
3	15	1.37E-08
4	14	2.05E-07
5	13	2.30E-06
6	12	1.99E-05
7	11	1.37E-04
8	10	7.52E-04
9	9	3.34E-03
10	8	1.20E-02
11	7	3.50E-02
12	6	8.16E-02
13	5	1.51E-01
14	4	2.15E-01
15	3	2.30E-01
16	2	1.72E-01
17	1	8.11E-02
18	0	1.80E-02
Sum		1.00000

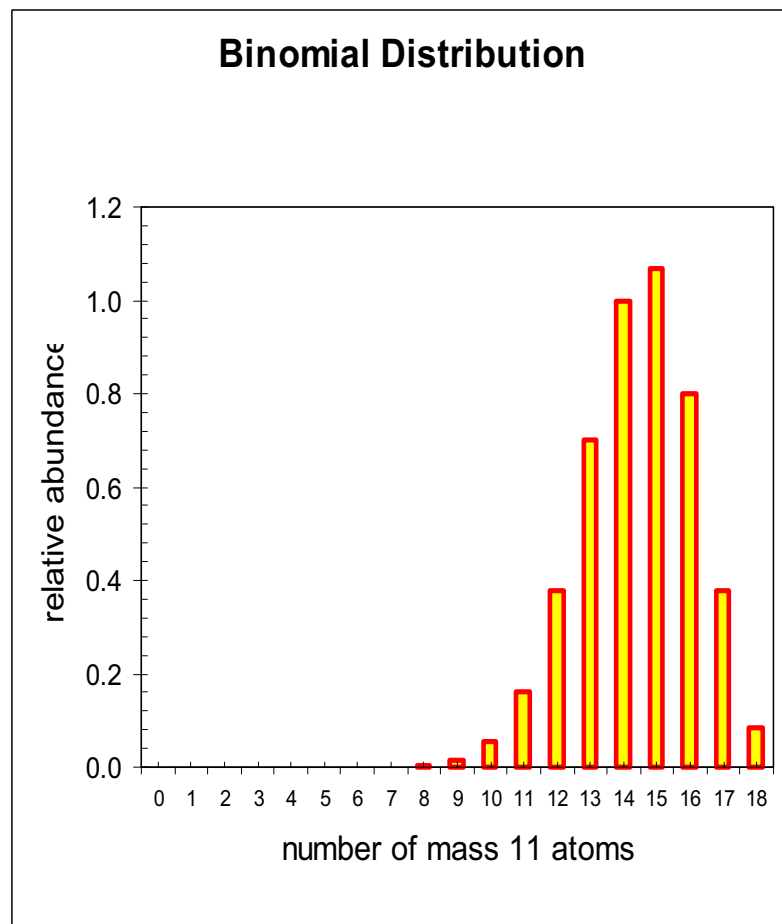

# Binomial Overlay

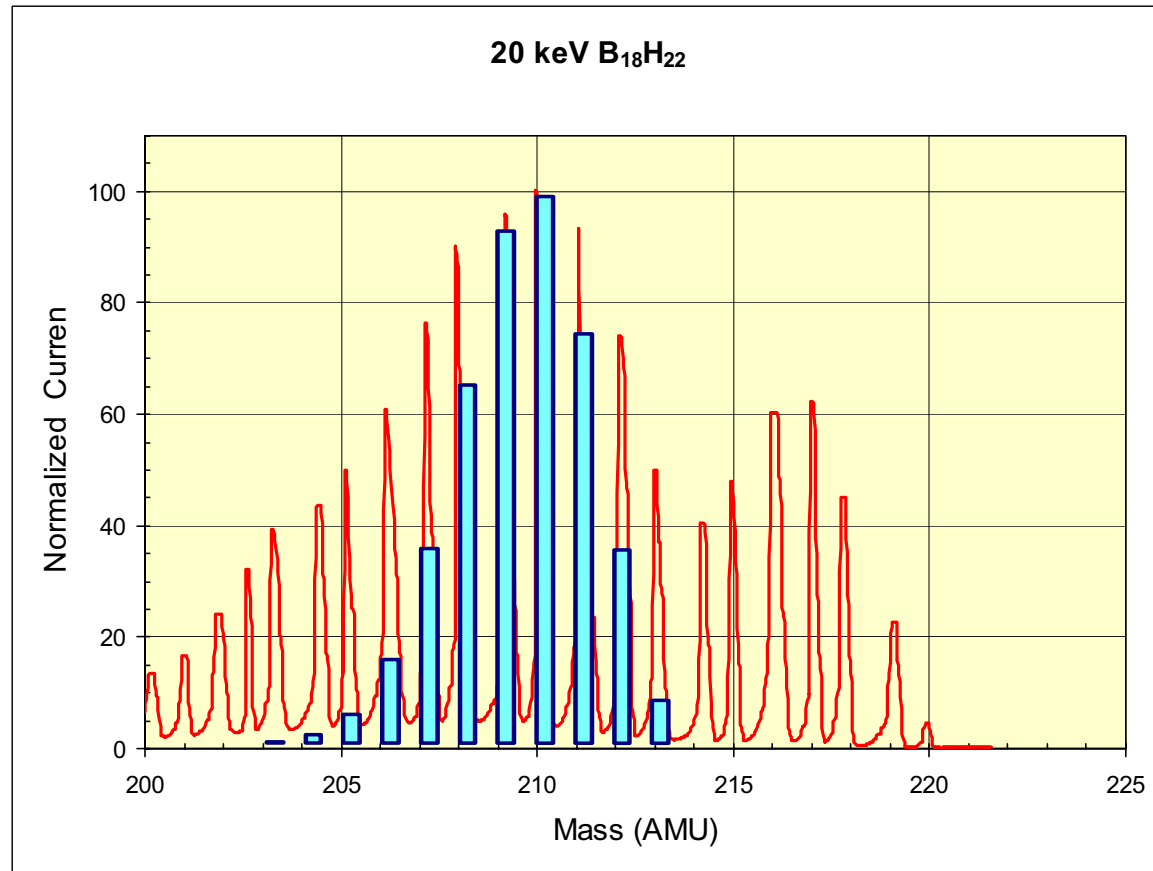

10 mm aperture at entrance to magnet, 0.5 mm Mass Resolving Aperture at focal plane

# Isotopically Enriched $^{11}\text{B}_{18}\text{H}_{22}$

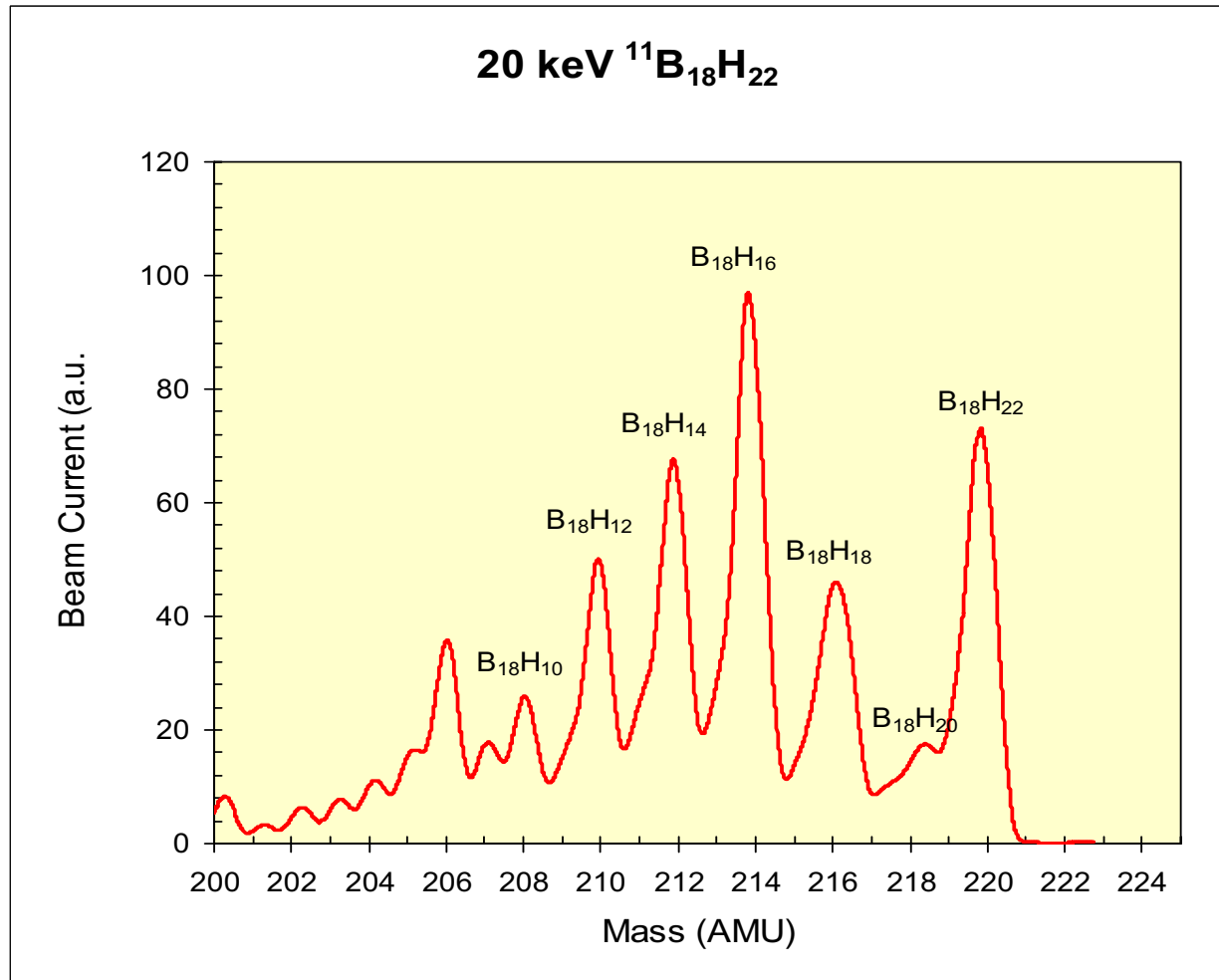

# Hydrogen Distribution Function

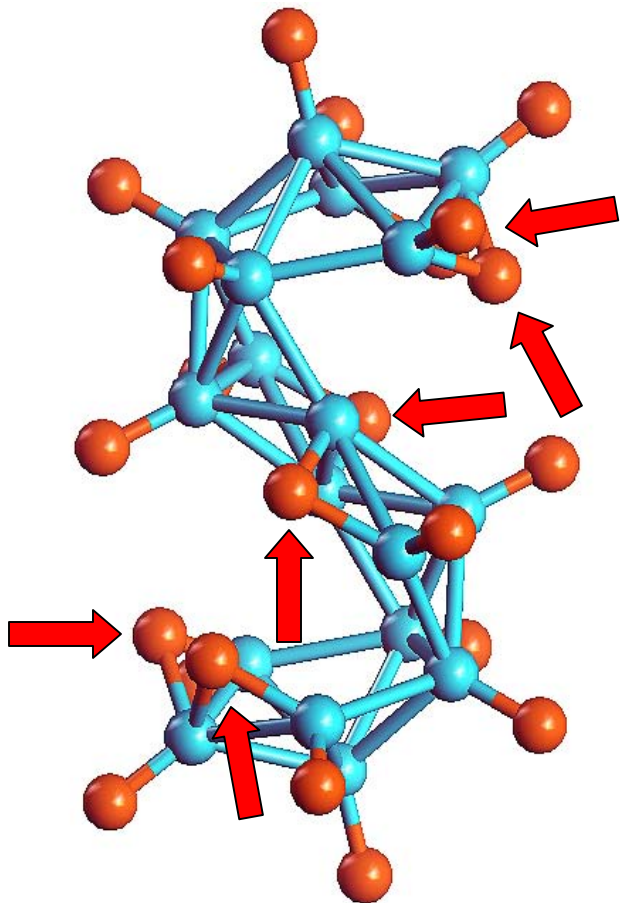

6 Bridge Hydrogen bonds

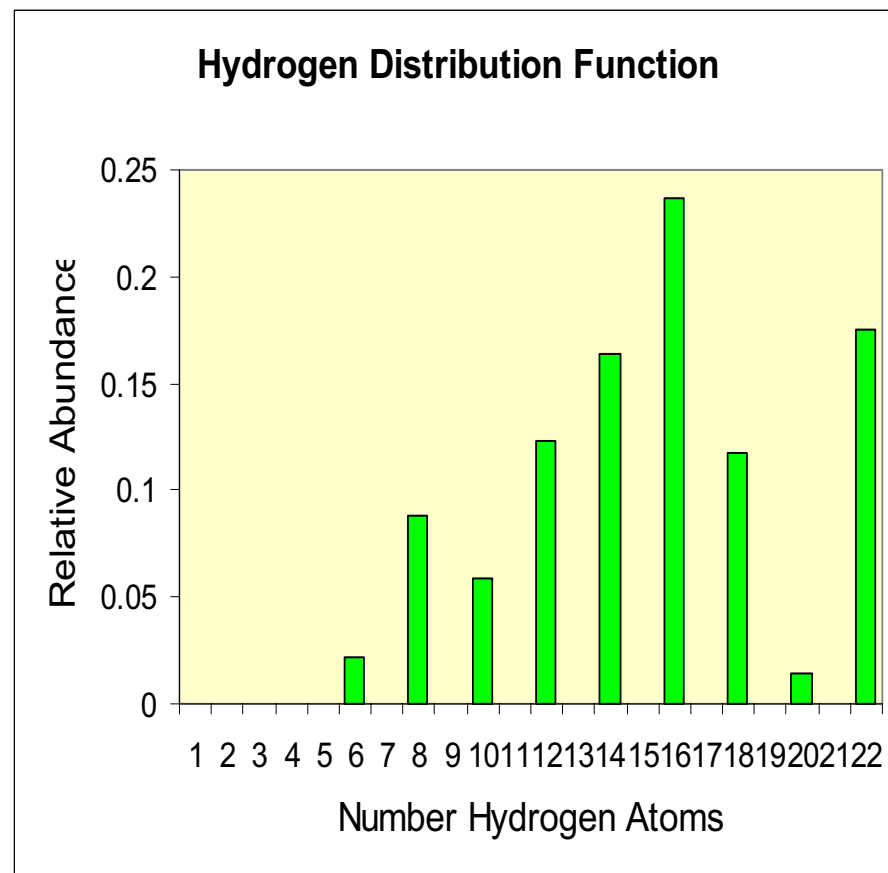

# Ultra-High Resolution Mass Spectrum

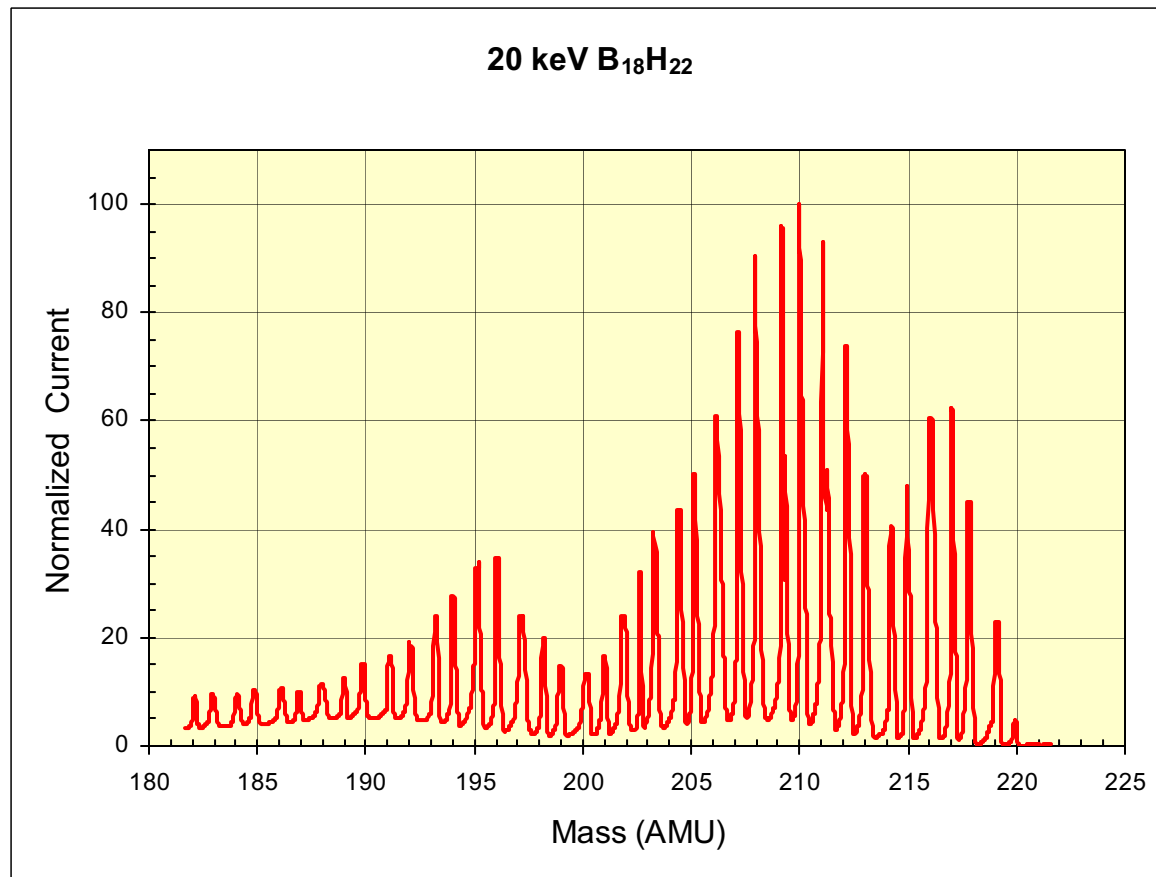

10 mm aperture at entrance to magnet, 0.5 mm Mass Resolving Aperture at focal plane

# Mass Resolving Aperture

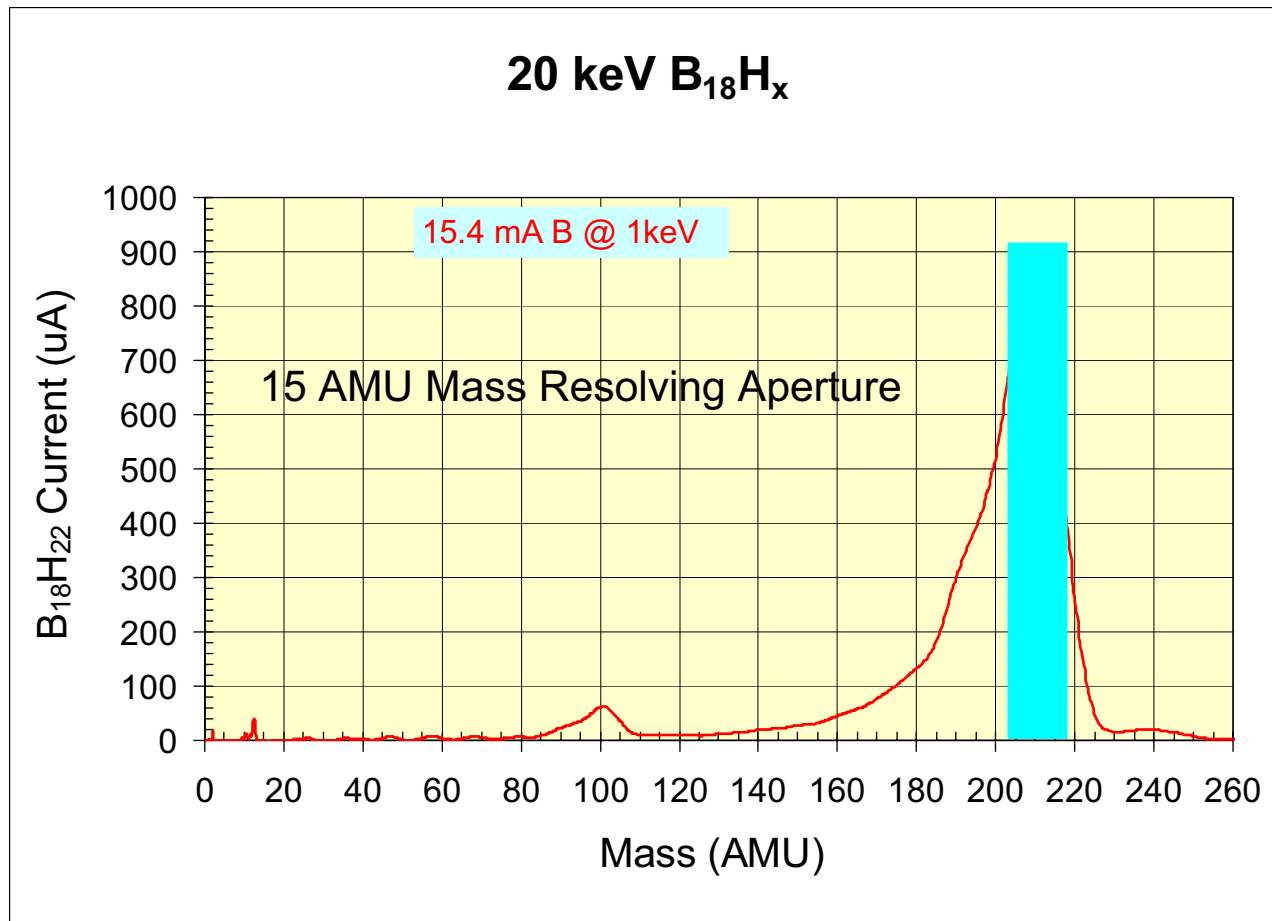

# Multiple Mass-Multiple Energy Analysis

- Simulation
  - 500 eV Equivalent Energy
  - $1 \times 10^{15}$  B/cm<sup>2</sup>
  - Assume Gaussian Profiles
  - Range and Straggle from SRIM
    - ▲ Linear Fit Over a few Hundred eV
    - ▲ Used Linear Regression to Calculate  $R_p$  and  $\Delta R_p$
- Used Measured & Calculated Distribution Functions (Binomial/Hydrogen/Mass Spectrum)
- 30 Unique Energies in the 15 AMU of Accepted Beam
- The Total distribution is the Sum of the 30 Mass Specific Depth Distributions
- Compare the Total Distribution to a Monomer Implant Distribution

# Range and Straggle Data

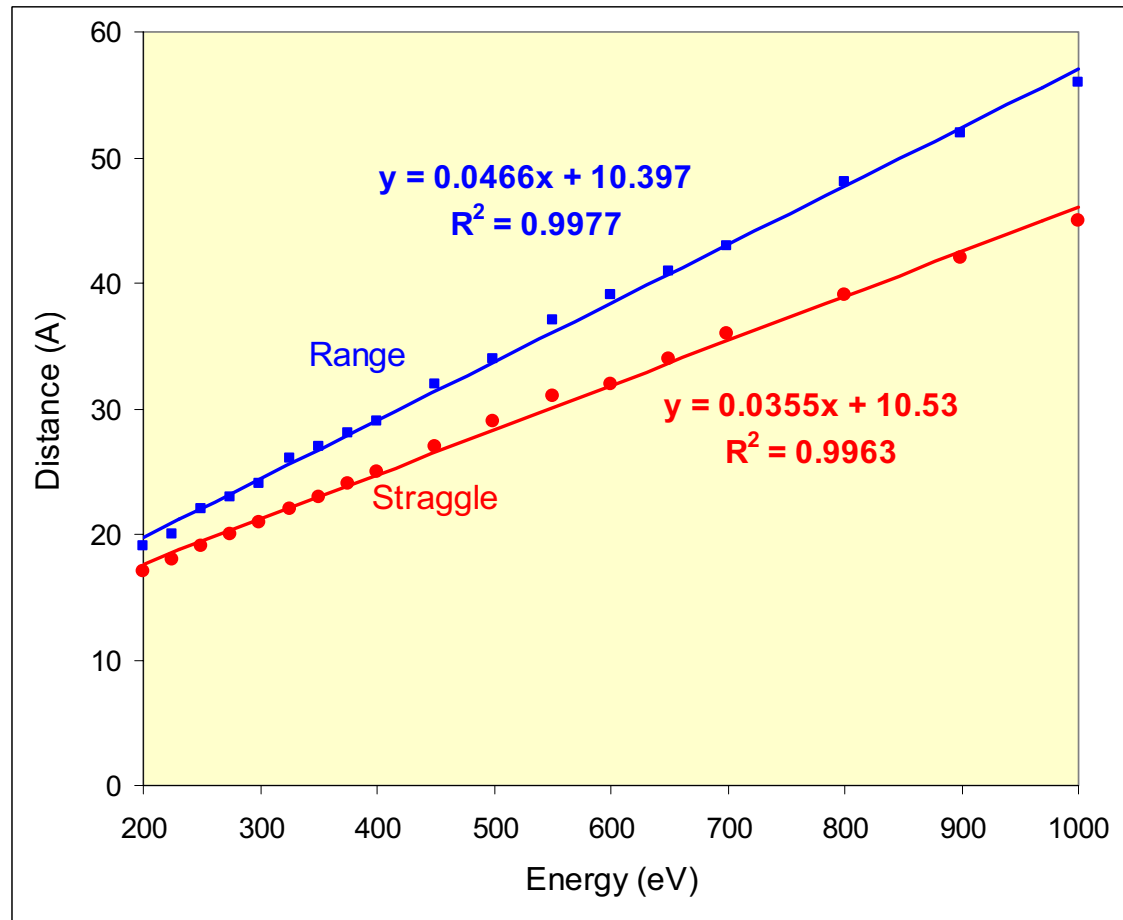

# 30 Discrete Energies

%	E	Range	Straggle
0.03327	0.45455	31.579	26.666
0.09980	0.45662	31.676	26.740
0.21496	0.45872	31.773	26.814
0.28661	0.46083	31.872	26.889
0.32755	0.46296	31.971	26.965
0.33574	0.46512	32.071	27.042
0.70424	0.46729	32.173	27.119
0.91715	0.46948	32.275	27.197
1.52906	0.47170	32.378	27.275
1.84678	0.47393	32.482	27.355
2.29717	0.47619	32.587	27.435
2.34405	0.47847	32.694	27.516
2.36821	0.48077	32.801	27.597
2.09685	0.48309	32.909	27.680
2.01486	0.48544	33.018	27.763
0.13307	0.50000	33.697	28.280
0.39920	0.50228	33.803	28.361
0.85983	0.50459	33.911	28.443
1.14643	0.50691	34.019	28.525
1.31021	0.50926	34.128	28.609
1.34297	0.51163	34.239	28.693
2.81695	0.51402	34.350	28.778
3.66859	0.51643	34.463	28.863
6.11623	0.51887	34.576	28.950
7.38713	0.52133	34.691	29.037
9.18867	0.52381	34.807	29.125
9.37620	0.52632	34.923	29.214
9.47282	0.52885	35.041	29.304
8.38740	0.53140	35.160	29.395
8.05943	0.53398	35.280	29.486

# 30 Energy Simulated Depth Profiles

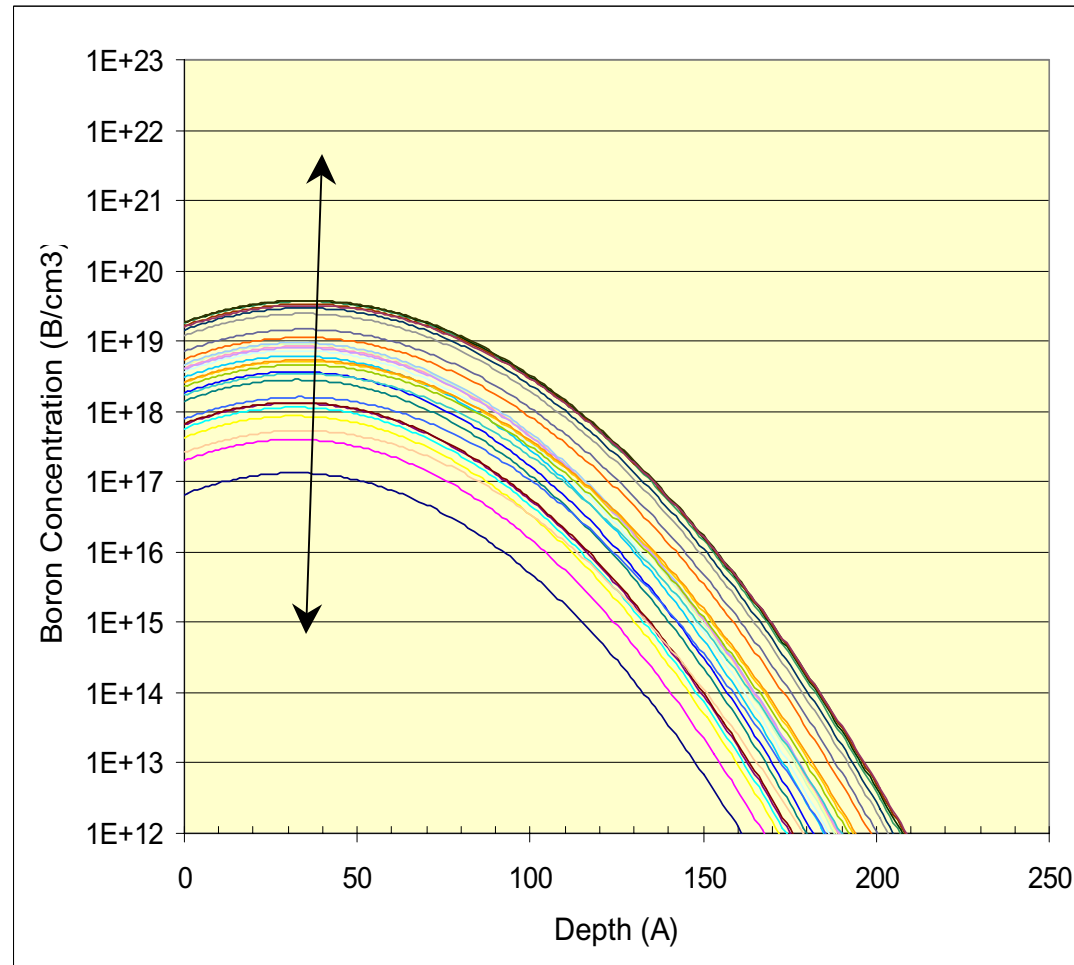

# 30 Energy Simulated Depth Profiles

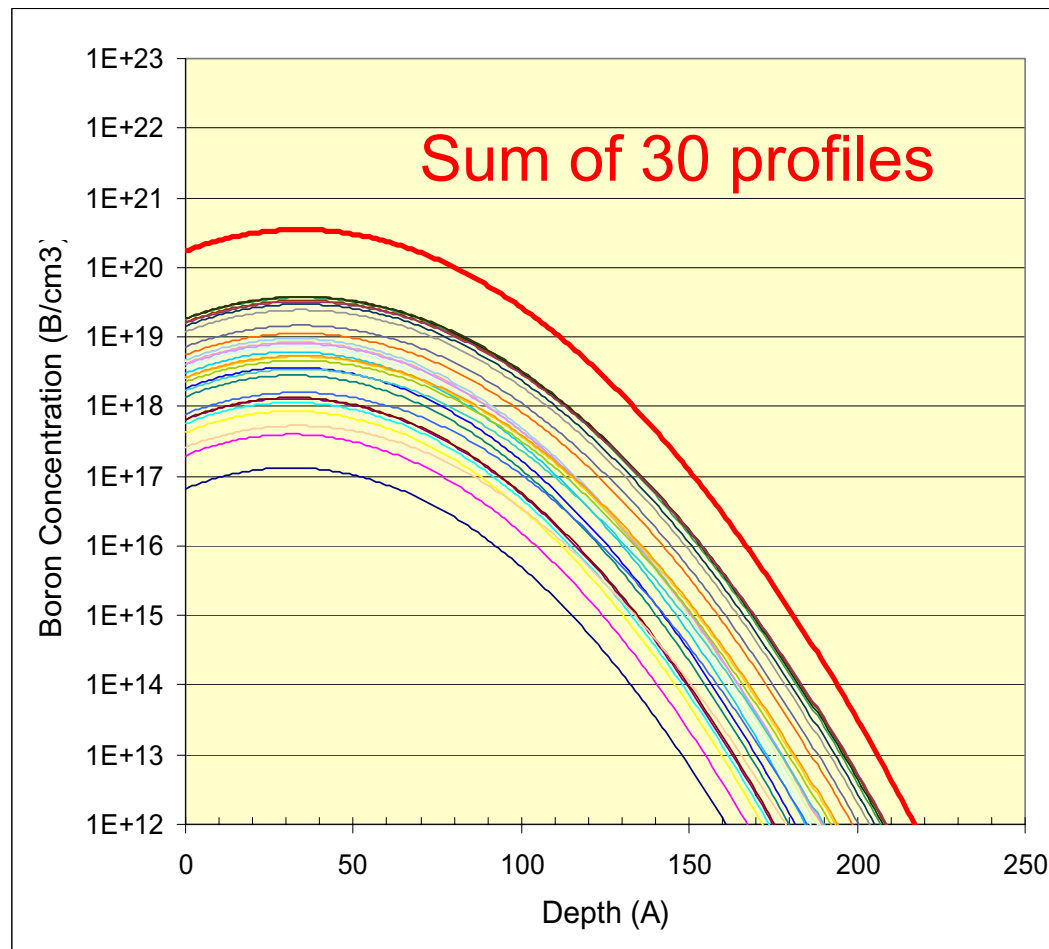

# 30 Energy Simulated Depth Profiles

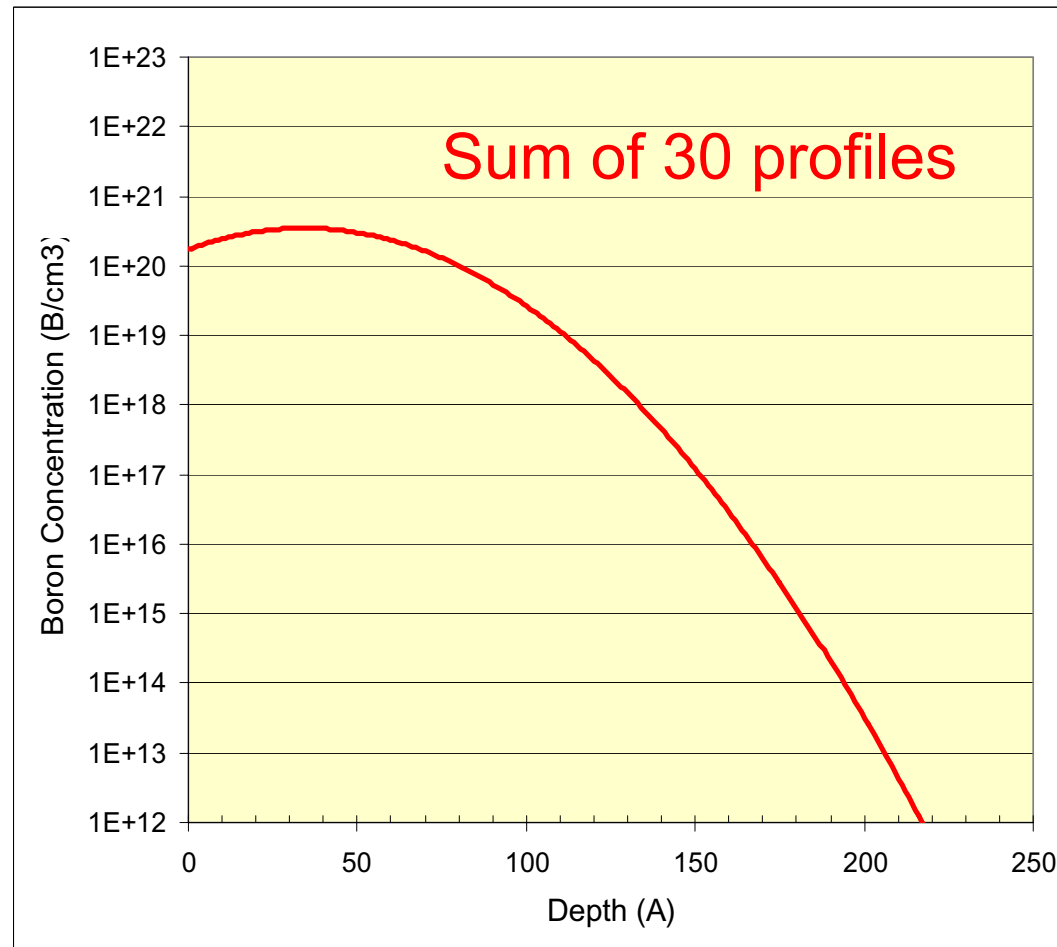

# 30 Energy Simulated Depth Profiles

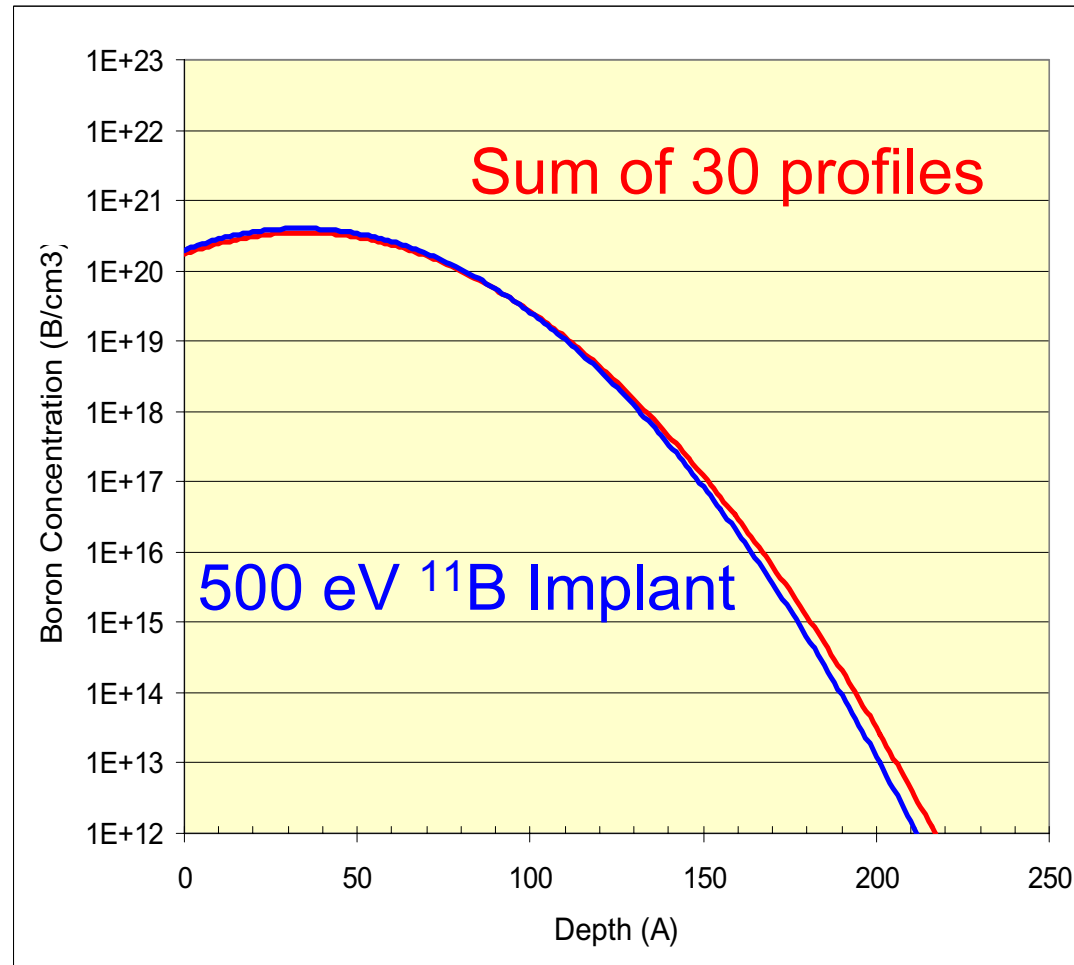

# 30 Energy Simulated Depth Profiles

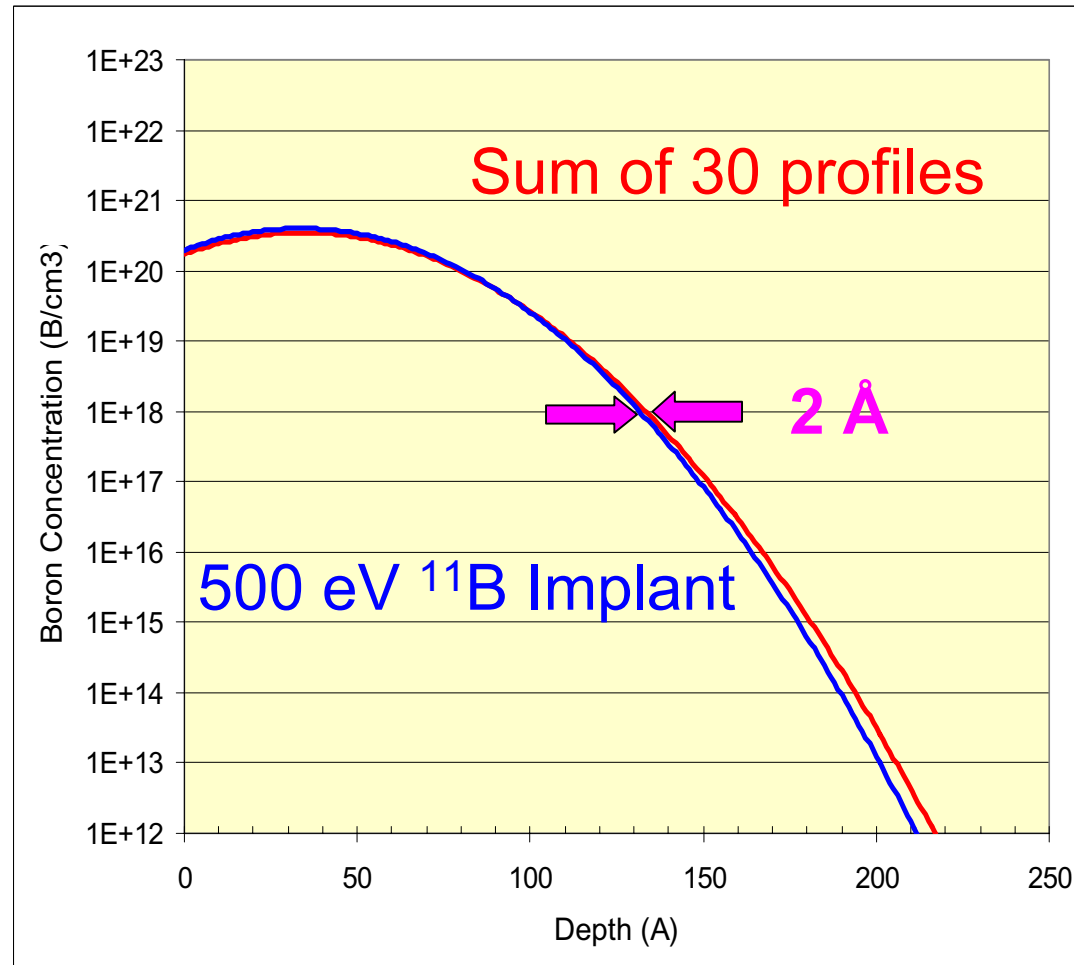

# Angular Divergence Due to Multiple Mass/Multiple Energy

---

- Axcelis GSD100 Implanter
- Analyzing Magnet
  - 70°
  - 538 mm Bending Radius
- 68% of the Current is in a 7 AMU wide Band Centered at Mass 210
- 8mR Half Divergence Angle
  - There is some spatial separation that is drift length dependent
  - Incident Angle Distribution Envelope is 8mR

# Summary

- The Binomial Distribution is Insufficient to Fit Mass Distribution of  $B_{18}H_{22}$
- The Hydrogen Distribution Significantly Contributes to the Mass Distribution
- Only Even Numbers of H Atoms Remain Bonded to the Octadecaborane Molecule When Ionized in the Clustelon<sup>®</sup> Source
- The Beam is Composed of 30 Distinct Energies
- The Multiple-Energy Effect on as Implanted Depth Profiles is Minimal,  $\sim 2\text{\AA}$  at 500 eV
- The Angular Divergence Due to the Multiple Mass/Multiple Energy Nature of the Beam is Very Small,  $\sim 8\text{mR}$